

3 PIECE FLANGE BALL VALVE

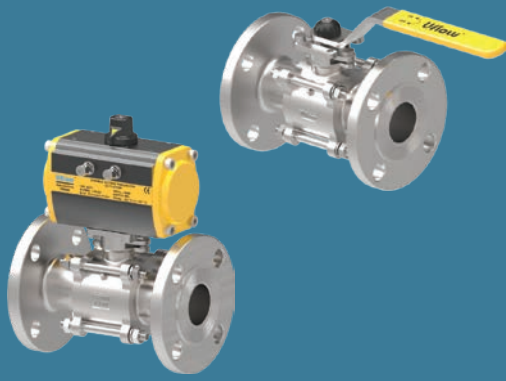

Diagram No. 6.1

SPECIFICATIONS

| | |
|-----------------------|--|
| End Connection : | Flange end, Butt weld |
| Face to Face : | ASME B 16.10 (Flange end) |
| Pressure Class : | 150# |
| Design Standard : | ASME B16.10, ASME B16.25, ASME B16.34, ASME B16.5, API 598, BS EN ISO 17292, ISO 5211 |
| Body Material : | CF8 / CF8M / WCB / CF3M |
| Tail Piece Material : | CF8 / CF8M / WCB / CF3M |
| Ball Material : | CF8 / CF8M |
| Body Seal Material : | PTFE / RPTFE / CFT / GFT / PEEK |
| Seat Ring Material : | PTFE / RPTFE / CFT / GFT / PEEK |
| Fastner Material : | SS304 / SS316 |
| Stem Seal Material : | PTFE / RPTFE / CFT / GFT / PEEK |
| Stem Material : | SS304 / SS316 / SS410 |
| Gland Bush Material : | SS304 / SS316 / SS410 |
| Gland Material : | SS304 / SS316 / SS410 |

FEATURES

- 3PC design twinseal ball valve.
- Full port ball valve.
- Blow out proof stem.
- Floating ball design.
- Hand Lever / Gear / Actuator Operated.
- Balls are precision machined and mirror finished for bubble-tight shut off with less operating torque.
- Face to Face:- ASME B16.10.
- End Connection:- Flanged (ASME B16.5), Butt weld (ASME B16.25).
- ISO 5211 top mounting pad available for easy Uflow make actuator mounting.

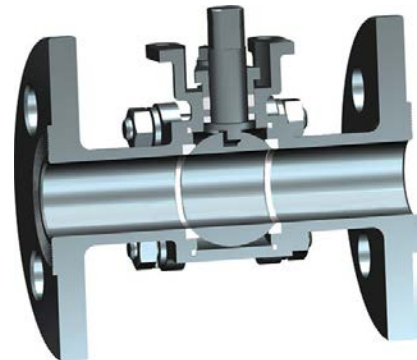

SECTION VIEW

DIMENSION

| Model No. | Diagram No. | Pipe (Inch) | A | B | CH | D | E | F | G | H | I | J | K | ISO 5211 |
|-----------|-------------|-------------|-----|--------|------|-------|--------|-----|--------|-------|-------|-------|---|----------|
| BCPC2AF(| 6.1 | ½" | 108 | 92 | 9.10 | 8.5 | 47 | 90 | 60.50 | 35 | 8 | 16 | 4 | F03 |
| BCPC3AF(| 6.1 | ¾" | 117 | 95 | 9.10 | 8.5 | 50 | 100 | 70 | 44.50 | 9 | 16 | 4 | F03 |
| BCPC4AF(| 6.1 | 1" | 127 | 117 | 11 | 13.5 | 61.50 | 110 | 79.50 | 51 | 9.60 | 16 | 4 | F05 |
| BCPC6AF(| 6.1 | 1½" | 165 | 136 | 11 | 13 | 73.50 | 125 | 98.50 | 73 | 12.50 | 16 | 4 | F05 |
| BCPC8AF(| 6.1 | 2" | 178 | 158 | 11 | 13 | 83 | 150 | 121 | 92 | 14.50 | 19 | 4 | F05 |
| BCPC9AF(| 6.1 | 2½" | 190 | 198.50 | 14 | 15 | 108.50 | 180 | 139.50 | 105 | 16 | 19.50 | 4 | F07 |
| BCPCAAF(| 6.1 | 3" | 203 | 218.50 | 17 | 20.50 | 123.50 | 190 | 152.50 | 127 | 17.50 | 19.50 | 4 | F07 |
| BCPCBAF(| 6.1 | 4" | 229 | 257.50 | 22 | 21.50 | 143 | 229 | 190.50 | 157 | 22.50 | 19 | 8 | F07 |

* AFM Stands For Flanged End Ball Valve With Handle

* AFB Stands For Flanged End Ball Valve Bare Stem (Without Handle)

* AFI Stands For Flanged End Ball Valve For #Actuators

For Actuators Check Catalogue Separately